

IMPORTANT NOTICE

If you have any problems with this unit,
contact Consumer Relations for service
PHONE: 1-800-275-8273.

Please read operating instructions
before using this product.

Please keep original box and packing materials
in the event that service is required.



W.P. APPLIANCES, INC.
Toll Free (800) 275-8273 Email address: wpappliances@ss2000.com
Website: www.wolfgangpuck-kitchenware.com

Model BMSD15BL Printed in China REV 2.0

All trademarks, service marks and trade names (collectively the "Marks") are proprietary to Wolfgang Puck World Wide.

WOLFGANG

PUCK

Blender
Attachment
(For use with
Stand Mixer
model BMSD0015)



Important Safeguards

When using electrical appliances, basic safety precautions should always be followed, including the following:

- 1 Read all instructions carefully.
- 2 To protect against risk of electrical shock, do not put cord, plug, or mixer body in water or other liquids.
- 3 Close supervision is necessary when any appliance is used by or near children.
- 4 Unplug from outlet when not in use, before putting on or taking off parts, and before cleaning.
- 5 Remove beaters and other attachments from mixer before washing.
- 6 Do not operate any appliance with a damaged cord or plug, or after the appliance malfunctions or is dropped or damaged in any manner. Return the appliance to an authorized service facility for examination, repair, or electrical or mechanical adjustment.
- 7 The use of accessory attachments not recommended or sold by W.P. Appliances, Inc. for use with this model may cause fire, electric shock or injury.
- 8 Avoid contacting moving parts. Keep hands, hair, and clothing, as well as spatulas and other utensils, away from beaters during operation to reduce risk of injury to persons, and/or damage to mixer.
- 9 Do not use outdoors.
- 10 Do not let cord hang over edge of table or counter. Do not let cord contact hot surfaces, including stove.
- 11 Do not place on or near a hot gas or electric burner, or in a heated oven.
- 12 Check that control is off before plugging cord into wall outlet. To disconnect, turn control to OFF, then grasp the plug and remove it from the outlet, never yank the cord to remove the plug.
- 13 Do not use appliance for other than intended purpose.

SAVE THESE INSTRUCTIONS

Table of Contents



Wolfgang Puck, owner of the famous Spago restaurants and one of the most influential chef-restauranteurs in America, is credited with reviving California's rich culinary heritage. His cooking innovations, a result of blending fresh

California ingredients with his classical French techniques, are enjoyed by world leaders, stars and fellow chefs alike. He established other trend-setting restaurants like Postrio in San Francisco, Chinois on Main in Santa Monica, Granita, Vert and Trattoria del Lupo. Home chefs can also share Mr. Puck's talents through his cookbooks and, of course, through his appliances!

| | |
|-------------------------------|----|
| Important Safeguards | 1 |
| About Wolfgang Puck | 3 |
| Know Your Blender | 5 |
| Before Your First Use | 6 |
| Helpful Hints | 6 |
| Assembling Your Blender | 7 |
| Disassembling Your Blender | 7 |
| Using Your Blender Attachment | 8 |
| Recipes | 9 |
| Limited Warranty | 21 |
| Contact Information | 23 |

Above Photo/Cover Photo Credit Alex Berliner - Berliner Studio

Know Your Blender

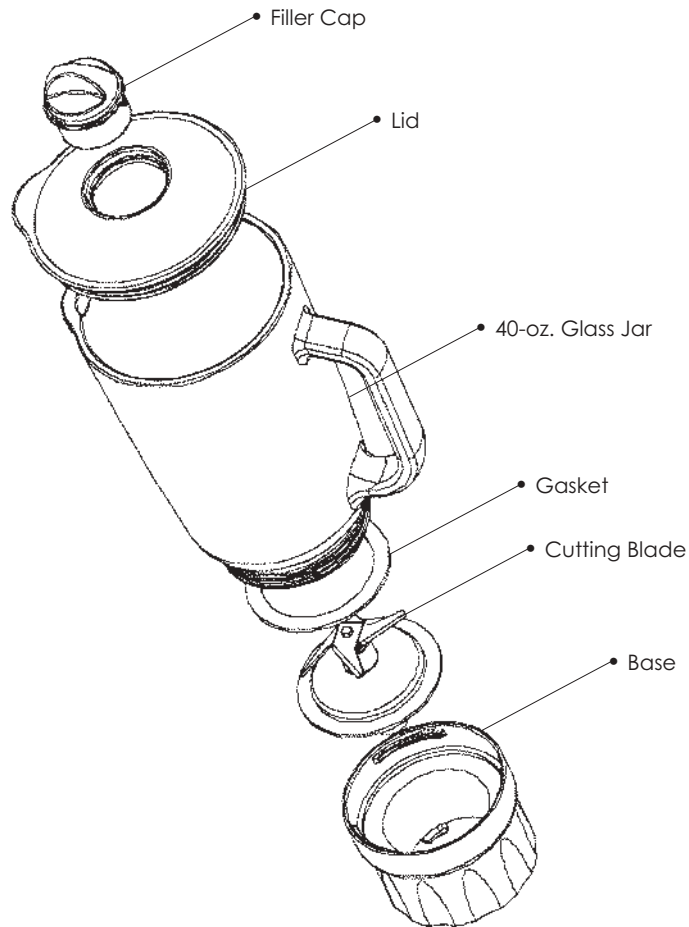

Your Wolfgang Puck blender attachment is perfect for processing smoothies, frozen drinks, soups, mayonnaise, breadcrumbs, and chopping nuts. We are sure that this appliance will bring you years of enjoyment in the kitchen.

Before Your First Use

Carefully unpack your blender and remove all packaging materials. Disassemble your blender (see Disassembling Blender in this manual) and wash all parts in warm soapy water.

Helpful Hints

- Never attempt to attach your blender to the power station while the motor is running.
- Always ensure that the blender is firmly attached to the base by holding the base firmly while turning the jar clockwise until tight.
- Never remove the blender, or its lid, until the blades have completely stopped moving.
- Never blend hot liquids.
- All food ingredients will be fully processed in less than a minute. Do not run your blender continuously for longer than one minute as you risk overheating the motor.
- Do not put dry ingredients into the blender before switching on. Cut into 1/2 inch cubes and drop them through the filler cap while the machine is running.
- The blender is not suitable as a storage container. Do not leave ingredients in the blender for an extended period of time.
- Never exceed the maximum capacity as marked on the jar.

Assembling Your Blender

IMPORTANT: The blade assembly and jar are subject to normal wear and tear due to everyday use. Prior to use, ensure that your blade assembly is not damaged, i.e. loose or cracked blades, and that your blender jar does not contain any cracks or chips. Should you notice any problems, discontinue use and contact our consumer hotline for replacement.

- 1 Place the blade assembly into the white base, and then place the gasket over the blade assembly. The gasket must lie flat on the blade assembly to ensure that no ingredients leak from your blender jar.
- 2 Hold the handle of the glass jar firmly while turning the white base counter clockwise.
- 3 Place filler cap into lid and rotate clockwise one half turn.

Disassembling Your Blender

- 1 Prior to disassembly of your blender attachment ensure that it is removed from the rear power hub of your stand mixer. When your ingredients have finished processing ensure that the blades have stopped moving prior to removing the blender. Remove the blender by holding the white base (not the jar) and turning counter clockwise. **DO NOT REMOVE THE BLENDER BY TURNING THE HANDLE ON THE JAR, AS THIS COULD LOOSEN THE JAR FROM THE BLENDER BASE CAUSING YOUR BLENDER JAR TO LEAK.**
- 2 After you have removed your blender from the rear power hub and have emptied its contents, hold the handle of the glass jar firmly while turning the white base clockwise.
- 3 Remove blades from the base, and gasket from the blade assembly. **USE CAUTION WHEN HANDLING THE BLADES AS THEY ARE SHARP AND CAN CAUSE INJURY.**
- 4 Remove filler cap from lid by turning in a counter-clockwise motion and lifting straight up.

Using Your Blender Attachment

- 1 Remove power cord from outlet by grasping the plug itself, never yank on cord to remove the plug.
- 2 Remove any mixing blade (Dough blade, flat paddle, or whisk) from the stand mixer head and ensure that the mixing bowl is firmly attached to the stand mixer, and free of any ingredients.

DO NOT place your hands near the front of the mixing head when using the blender as the planetary head will rotate while blending in the rear power hub. Do not wear dangling jewelry, or loose clothing, nor have hair hanging anywhere near the stand mixer. **SERIOUS INJURY CAN OCCUR IF YOU DO NOT FOLLOW THESE INSTRUCTIONS.**

- 3 Lower the mixer head until it clicks shut.
- 4 Remove the rear outlet cover by putting slight downward pressure and twisting counter-clockwise.
- 5 Add your ingredients into the jar.
- 6 Place the lid and filler cap onto the jar.
- 7 Never attempt to attach your blender to the power hub while the motor is on.
- 8 Attach the jar by placing the jar on the rear power hub and twisting it clockwise until it locks into place.
- 9 Plug the unit into an outlet to switch on and process your ingredients.
- 10 When your ingredients have finished processing ensure that the blades have stopped moving prior to removing the blender. Remove the blender by holding the white base (not the jar) and turning counter clockwise. **DO NOT REMOVE THE BLENDER FROM THE STAND MIXER BY TURNING THE HANDLE ON THE JAR, AS THIS WILL LOOSEN THE JAR FROM THE BLENDER BASE CAUSING YOUR BLENDER TO LEAK.**

Banana-Strawberry Frappe

Serves 1

INGREDIENTS

- 1 cup cold milk
- 8 ounces strawberry yogurt
- 2 bananas
- 1 tablespoon lemon juice

METHOD

- 1 Add all ingredients into blender.
- 2 Put blender on stand and twist handle to lock.
- 3 Turn dial to speed 8, blend to desired consistency.
- 4 Serve in tall glass.

Recipe courtesy Debra Murray (Wolfgang Puck HSN Guest Host)

Blueberry Margarita

Serves 2

INGREDIENTS

- 2 1/2 cups ice
- 4 ounces tequila
- 2 ounces blue Curacao
- 3 ounces sweetened lime juice
- 1/2 cup partially frozen blueberries

METHOD

- 1 Put all ingredients into blender.
- 2 Put blender on stand and twist handle toward you to lock.
- 3 Cover and blend (you may need to pulse on and off to get things started). Mix on speed 10 until smooth, about 20 seconds.
- 4 Pour into a frosty margarita glass (you can dip rim of glass in granulated sugar) and enjoy.

Recipe courtesy Debra Murray (Wolfgang Puck HSN Guest Host)

Gazpacho

Serves 6

INGREDIENTS

3 large tomatoes
1 red bell pepper
1 medium cucumber
1 small onion
4 cloves garlic
1 slice bread
1 cup water
1/2 teaspoon cumin
1/8 teaspoon paprika
4 tablespoons red wine
1 teaspoon salt
1/4 teaspoon ground black pepper, to taste

METHOD

- 1 With a sharp knife, coarsely chop vegetables and bread, and finely chop garlic.
- 2 Put a handful of mixed vegetables, garlic, bread and some of the water into blender. Put blender on stand and twist handle toward you to lock. Keep pressing pulse for about 10 seconds.
- 3 Put rest of vegetables, garlic, bread and water by handfuls into the blender and blend well on speed 10, but not to the point of pureeing. Don't over blend, you still want some texture.
- 4 Pour blended mixture in to a bowl and whisk in remaining ingredients.
- 5 Chill in refrigerator for half an hour before serving.

Recipe courtesy Debra Murray (Wolfgang Puck HSN Guest Host)

Creamsicle Freeze

Serves 2

INGREDIENTS

2 cups orange juice
1 cup water
2 tablespoons powdered coffee creamer
1/2 cup sugar
14 full sized ice cubes
1 teaspoon vanilla extract
1 peeled orange, for extra flavor (optional)

METHOD

- 1 Put all ingredients into blender.
- 2 Put blender on stand and twist handle toward you to lock. Mix on speed 8 until no ice chunks are left (might need to pulse several times to get started).

SERVING IDEAS

Strawberries and cream version: Replace orange juice with strawberries (or any other kind of berry)

NOTES: Do not replace powdered creamer with real milk as acid from the orange juice will cause milk to curdle.

Recipe courtesy Debra Murray (Wolfgang Puck HSN Guest Host)

Peachy Yogurt Cooler

Serves 2

INGREDIENTS

- 1/2 cup milk
- 1 6 ounce container low-fat peach yogurt
- 1 medium fresh peach, peeled, pitted and chopped
- 1 dash ground nutmeg

METHOD

- 1 Put milk, yogurt, and peach into blender.
- 2 Put blender on stand and twist handle toward you to lock. Mix on speed 8 until smooth (about 30 seconds).
- 3 Sprinkle with nutmeg and serve.

Recipe courtesy Debra Murray (Wolfgang Puck HSN Guest Host)

Mandarin Frosty

Serves 1

INGREDIENTS

- 1/2 cup cold milk
- 1/2 cup canned mandarin orange slices
- 1 scoop orange sherbet

METHOD

- 1 Put all ingredients into blender. Put blender on stand and twist handle toward you to lock.
- 2 Mix on speed 8 until smooth.
- 3 Serve in tall glass.

Recipe courtesy Debra Murray (Wolfgang Puck HSN Guest Host)

Simple Mango Smoothie

Serves 1

INGREDIENTS

1/2 cup mangos, diced, frozen
2/3 cup milk
1/2 teaspoon sugar or honey, more to taste

METHOD

- 1 Put all ingredients into blender.
- 2 Put blender on stand and twist handle toward you to lock. Turn dial to speed 8, blend until smooth, adding a bit more milk if needed.
- 3 Serve and enjoy.

NOTES: To make a larger smoothie or to make more servings, just use equal amounts of mango and milk, plus sugar to taste.

Recipe courtesy Debra Murray (Wolfgang Puck HSN Guest Host)

Pumpkin Shake

Serves 4

INGREDIENTS

3 cups vanilla ice cream
1 1/2 cups milk
1 15 ounce can solid pack pumpkin
1/4 cup light corn syrup
1 teaspoon vanilla extract
1/4 teaspoon ground cinnamon
1/4 teaspoon ground cloves

METHOD

- 1 Put all ingredients into blender. Put blender on stand and twist handle toward you to lock.
- 2 Mix on speed 8 until thoroughly mixed.
- 3 Serve immediately.

SERVING IDEAS

If desired, you can top each serving with a dollop of whipped cream and a sprinkle of cinnamon.

Recipe courtesy Debra Murray (Wolfgang Puck HSN Guest Host)

Berry Berry Smoothie

Serves 2

INGREDIENTS

- 1 3/4 cups low-fat blueberry yogurt
- 1/4 cup grape juice
- 1 1/2 cups frozen blueberries
- 1 1/2 cups frozen blackberries

METHOD

- 1 Add yogurt and juice to the blender jar.
- 2 Blend to combine ingredients.
- 3 Increase to speed 7 and add berries through the lid by removing the filler cap.
- 4 Blend to desired consistency.
- 5 Pour into glasses and serve immediately.

Recipe courtesy Debra Murray (Wolfgang Puck HSN Guest Host)

Frappe Cappuccino

Serves 2

INGREDIENTS

- 3/4 cup cold double-strength coffee
- 1 cup milk
- 2 cups ice cubes
- 3 Tablespoons sugar

METHOD

- 1 Put all ingredients into blender.
- 2 Put blender on stand and twist handle toward you to lock. Mix on speed 10 until smooth.

Recipe courtesy Debra Murray (Wolfgang Puck HSN Guest Host)

Red, White and blue Milk Shake

Serves 4

INGREDIENTS

1 quart strawberry ice cream
1 cup milk (2 cups if you like your shakes thinner)
1/2 cup strawberry preserves
1/4 cup frozen whipped topping
1/4 cup fresh blueberries, washed

METHOD

- 1 Put ice cream, Milk and preserves into blender.
- 2 Put blender on stand and twist handle toward you to lock. Turn dial to speed 8 until well combined (about a minute).
- 3 Pour into glasses and top each with a dollop of whipped topping.
- 4 Top with blueberries and serve immediately.

Recipe courtesy Debra Murray (Wolfgang Puck HSN Guest Host)

Maple Leaf Milkshake

Serves 1

INGREDIENTS

1 cup cold milk
1 scoop maple walnut ice cream
2 tablespoons chocolate syrup

METHOD

- 1 Put all ingredients into blender. Put blender on stand and twist handle toward you to lock.
- 2 Mix on speed 8 until smooth.

Recipe courtesy Debra Murray (Wolfgang Puck HSN Guest Host)

Limited Warranty

This warranty covers all defects in workmanship or materials in the mechanical and electrical parts, arising under normal usage and care, in this product for a period of 12 months from the date of purchase provided you are able to present a valid proof-of-purchase. A valid proof-of-purchase is a receipt specifying item, date purchased, and cost of item. A gift receipt with date of purchase and item is also an acceptable proof-of-purchase.

This warranty covers the original retail purchaser or gift recipient. During the applicable warranty period within normal household use, we will repair or replace, at our discretion, any mechanical or electrical part which proves defective, or replace unit with a comparable model.

To obtain service under the terms of this warranty, call Toll Free (800) 275-8273.

THIS LIMITED WARRANTY COVERS UNITS PURCHASED AND USED WITHIN THE UNITED STATES AND DOES NOT COVER:

- Damages from improper installation.
- Defects other than manufacturing defects.
- Damages from misuse, abuse, accident, alteration, lack of proper care and maintenance, or incorrect current or voltage.
- Damage from service by other than an authorized dealer or service center.

This warranty gives you special legal rights and you may also have other rights to which you are entitled which may vary from state to state.